

## L-Band Avionics Transistor

The high power pulsed avionics transistor part number IB1012S150 is designed for L-Band avionics systems operating at 1025 to 1150 MHz. While operating in class C mode under DME pulse conditions at  $V_{CC}=50V$ , this common base device supplies a minimum of 150 watts of peak pulse power. It utilizes a low loss internal input impedance matching structure to yield maximum device gain and to ease the implementation of external matching circuitry. The new generation bipolar transistor geometry utilizes a gold metallization system to achieve maximum reliability. Emitter ballast resistance is incorporated on the active cell for optimum thermal distribution and maximum reliability. All devices are 100% screened for large signal RF parameters.



### Silicon Bipolar

- Ultra-high  $f_T$

### Class C Operation

- High Efficiency

### Common Base Configuration

- Single Power Supply

### Gold Metal

- Maximum Reliability

### Emitter Ballasting

- Optimum Thermal Distribution

### Internal Impedance Matching

- Ease of Use
- Ultra-low Loss Design

### BeO Package

- Unmatched Thermal Reliability

### RF Test Fixture

- Broadband
- Matched to  $50\Omega$
- Long-term Correlation
- 100% Device RF Screening
- No External Tuning Allowed
- Micro-strip structure on soft pc board with dielectric constant 10.5

*TYPICAL DATA*

*TYPICAL DATA*

*TYPICAL DATA*

*TYPICAL DATA*

Device	Freq (MHz)	$V_{CC}$ (V)	$P_{IN}$ (W)	IRL (dB)	$P_{OUT}$ (W)	$G_P$ (dB)	$I_C$ (A)	$\eta_C$ (%)	Droop (dB)
D4019-1	1025	50	12	11	173	11.6	6.5	53.2	< 0.1
	1090	50	12	11	173	11.6	6.4	54.1	< 0.1
	1150	50	12	12	157	11.2	6.0	52.3	< 0.1

Pulse Format = DME (10 $\mu$ s, 1%)

Power measurements made using Boonton 4500 Peak Power Analyzer

**MAXIMUM RATINGS**

Screen	Parameter	Symbol	Min	Max	Units	Test Conditions
BD	Collector-Emitter Voltage	$V_{CES}$	--	85	V	--
BD	Emitter-Base Voltage	$V_{EBO}$	--	2	V	--
BD	Storage Temperature Range	$T_{STG}$	-55	+150	°C	--
BD	Operating Junction Temperature Range	$T_J$	-55	+200	°C	--
Note	Screen 'BD' = parameter qualified By Design.					

**THERMAL CHARACTERISTICS**

Screen	Parameter	Symbol	Min	Max	Units	Test Conditions
BD	Thermal Resistance	$R_{TH(JC)}$	--	TBD	°C/W	$V_{CC}=50V$ , Pulse format 10 $\mu$ s, 1%, $T_F=25\pm 5^\circ C$ , $P_{IN}=12W$ , $N_C=50\%$
Note	Screen 'BD' = parameter qualified By Design.					

**PROCESSING SPECIFICATIONS**

Screen	Parameter	Symbol	Min	Max	Units	Test Conditions
100%	DC Wafer Probe	--	--	--	--	Per Integra specification.
Q1	Wafer DC and RF Qualification	--	--	--	--	Per Integra specification.
LM	Wire Bond Strength	--	--	--	--	Line monitor per Integra specification.
100%	Pre-cap visual inspection	--	--	--	--	Per Integra specification
100%	Gross leak test	--	--	--	--	MIL-STD-750D, Method 1071, Test Condition C
Note	Screen 'Q1' = parameter is qualified by assembly and test of 3 pieces minimum per wafer.					
Note	Screen 'LM' = parameter is qualified by assembly line monitor.					

**DC ELECTRICAL CHARACTERISTICS**

Screen	Parameter	Symbol	Min	Max	Units	Test Conditions
100%	Collector-Emitter Breakdown Voltage	$BV_{CES}$	85	--	V	$I_C = 10mA$ , $V_{BE} = 0V$ , $T_F = 25\pm 5^\circ C$ .
100%	Zero Base Voltage Collector Leakage Current	$I_{CES}$	--	8	mA	$V_{CE} = 50V$ , $V_{BE} = 0V$ , $T_F = 25\pm 5^\circ C$ .
100%	DC Current Gain	$H_{FE}$	5	100	--	$V_{CE} = 5V$ , $I_C = 200mA$ , $T_F = 25\pm 5^\circ C$ .

**RF ELECTRICAL CHARACTERISTICS**

Screen	Parameter	Symbol	Min	Max	Units	Test Conditions
100%	Input Return Loss	IRL	9	--	dB	$V_{CC}=50V$ , $P_{IN}=12W$ , Pulse = Note 2, $T_F=25\pm5^\circ C$ , $F=F1$ .
BD	Maximum Overdrive	$P_{IN(MAX)}$	--	16	W	$V_{CC}=50V$ , Pulse = Note 2, $T_F=25\pm5^\circ C$ , $F=F1$ .
100%	Power Gain	$G_P$	11	12.5	dB	$V_{CC}=50V$ , $P_{IN}=12W$ , Pulse = Note 2, $T_F=25\pm5^\circ C$ , $F=F1$
100%	Gain Flatness	dG	--	1.5	dB	$V_{CC}=50V$ , $P_{IN}=12W$ , Pulse = Note 2, $T_F=25\pm5^\circ C$ , $F=F1$
100%	Output Power	$P_{out}$	150	214	W	$V_{CC}=50V$ , $P_{IN}=12W$ , Pulse = Note 2, $T_F=25\pm5^\circ C$ , $F=F1$
100%	Collector Efficiency ( $P_o/I_c/V_{CC}$ )	$N_C$	50	--	%	$V_{CC}=50V$ , $P_{IN}=12W$ , Pulse = Note 2, $T_F=25\pm5^\circ C$ , $F=F1$ .
100%	Pulse Amplitude Droop	D	--	0.5	dB	$V_{CC}=50V$ , $P_{IN}=12W$ , Pulse = Note 2, $T_F=25\pm5^\circ C$ , $F=F1$ .
100%	Stability into 1.5:1 VSWR	VSWR-S	--	--	--	$V_{CC}=50V$ , $P_{IN}=12W$ , Pulse = Note 2, $T_F=25\pm5^\circ C$ , $F=F1$ . Rotate 1.5:1 output VSWR through 360° phase. No oscillatory or pulse break-up characteristics allowed on detected output pulse.
100%	Load Mismatch Tolerance	LMT	3:1	--	--	$V_{CC}=50V$ , $P_{IN}=12W$ , Pulse = Note 2, $T_F=25\pm5^\circ C$ , $F=F1$ . Rotate 3:1 output VSWR through 360° phase. Survival.
BD	Pulse Risetime	RT	--	80	ns	$V_{CC}=50V$ , $P_{IN}=12W$ , Pulse = Note 2, $T_F=25\pm5^\circ C$ , $F=F1$ . Measure between 10% and 90% detected power points.
Note 1	F1 = 1025/1090/1150 MHz.					
Note 2	Pulse format = 10µs, 1%					
Note 3	$T_F$ = Device flange temperature.					
Note 4	Screen 'BD' = parameter qualified By Design.					

**RF TEST FIXTURE IMPEDANCE CHARACTERISTICS**

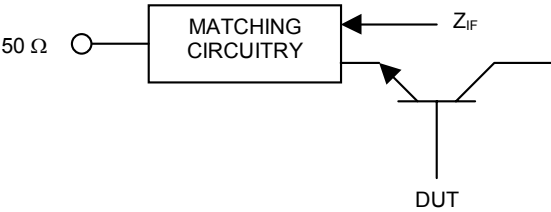
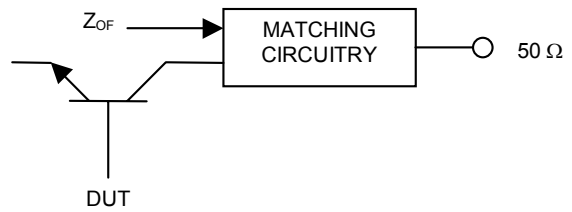
Frequency (MHz)	$Z_{IF}$ ( $\Omega$ )	$Z_{OF}$ ( $\Omega$ )
1025	12.52 -j 7.84	4.94 -j0.13
1090	8.63 -j 3.11	5.31 -j0.17
1150	8.27 +j 1.48	5.51 -j0.4
Impedance Definition		

**PACKAGE DIMENSIONAL OUTLINE DRAWING**

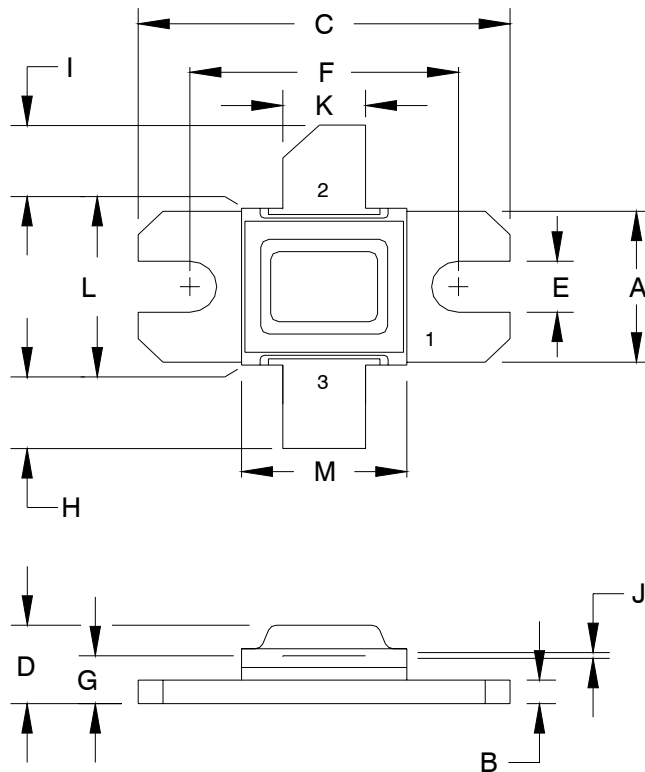

DIM	INCHES		MILLIMETERS	
	MIN	MAX	MIN	MAX
A	0.380	0.390	9.65	9.91
B	0.058	0.062	1.47	1.57
C	0.895	0.905	22.73	22.99
D	0.195	0.205	4.95	5.21
E	0.125	0.135	3.18	3.43
F	0.645	0.655	16.38	16.64
G	0.112	0.132	2.84	3.35
H	0.207	0.247	5.25	6.27
I	0.207	0.247	5.25	6.27
J	0.003	0.005	0.08	0.13
K	0.195	0.205	4.95	5.21
L	0.395	0.405	10.03	10.29
M	0.395	0.405	10.03	10.29

PIN	
1	BASE
2	COLLECTOR
3	EMITTER

**RF TEST FIXTURE**

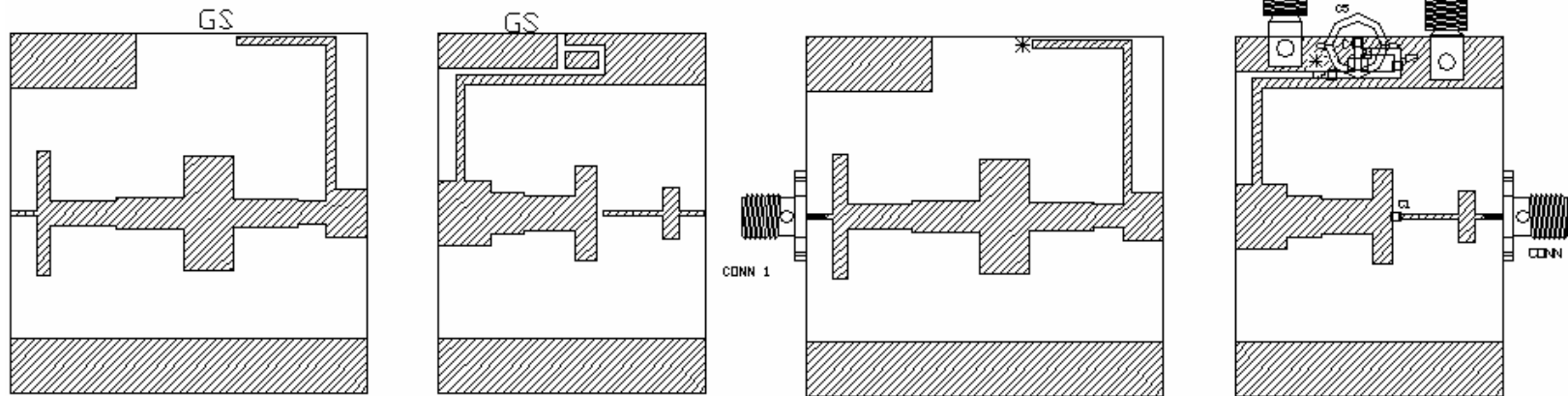

COMPONENT	DESCRIPTION
Q1	TRANSISTOR #IB1012S150 MOUNT HARD TO THE RIGHT
PC BOARD	ROGERS #R03010, TH=0.025" 1oz, Cu
C1,C2	CHIP CAPACITOR, TYPE ATC100A, 100 pF
C3	CHIP CAPACITOR 2.2uF
C4	TANTALUM CAPACITOR AV X 4.7uF, 50V, ESR=0.3 ohm
C5	ELECTROLYTIC CAPACITOR 68uF / 6.3V
C6 (NOT SHOWN)	ELECTROLYTIC CAPACITOR 4700uF / 80V
R1	CHIP RESISTOR 10ohms
GS	GROUND SHIM, COPPER, TH=0.001"
CONN1, CONN2	SMA CONNECTOR, TYPE DS #2052-5636-02
INPUT PC BOARD CARRIER	2 INCH BRASS - 07 (2.00")
OUTPUT PC BOARD CARRIER	2 INCH BRASS - 05 (1.50")
TRANSISTOR CARRIER	2 INCH COPPER - 02 (P44)
TRANSISTOR CLAMP	WOLLY CLAMP - 02 (P44)
ALUMINUM HEATSINK	2 INCH HEATSINK - 11
DC CONN1	BANANA JACK, BLACK
DC CONN2	BANANA JACK, RED
NOTE	FIXTURE HARDWARE DRAWINGS AVAILABLE ON REQUEST

**ASSEMBLY AND PARTS LIST**

**RF TEST FIXTURE**

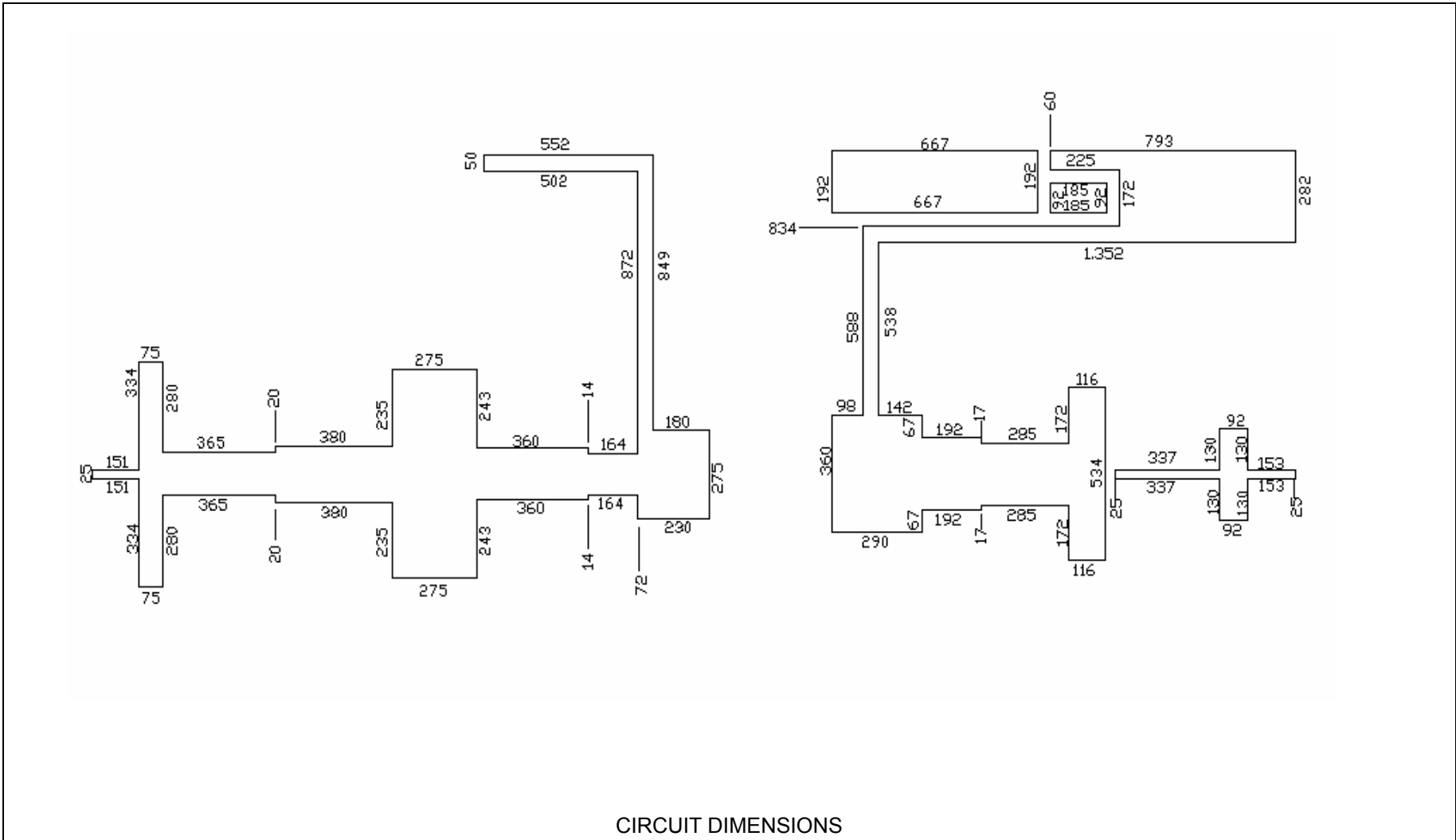

**RF TEST FIXTURE**

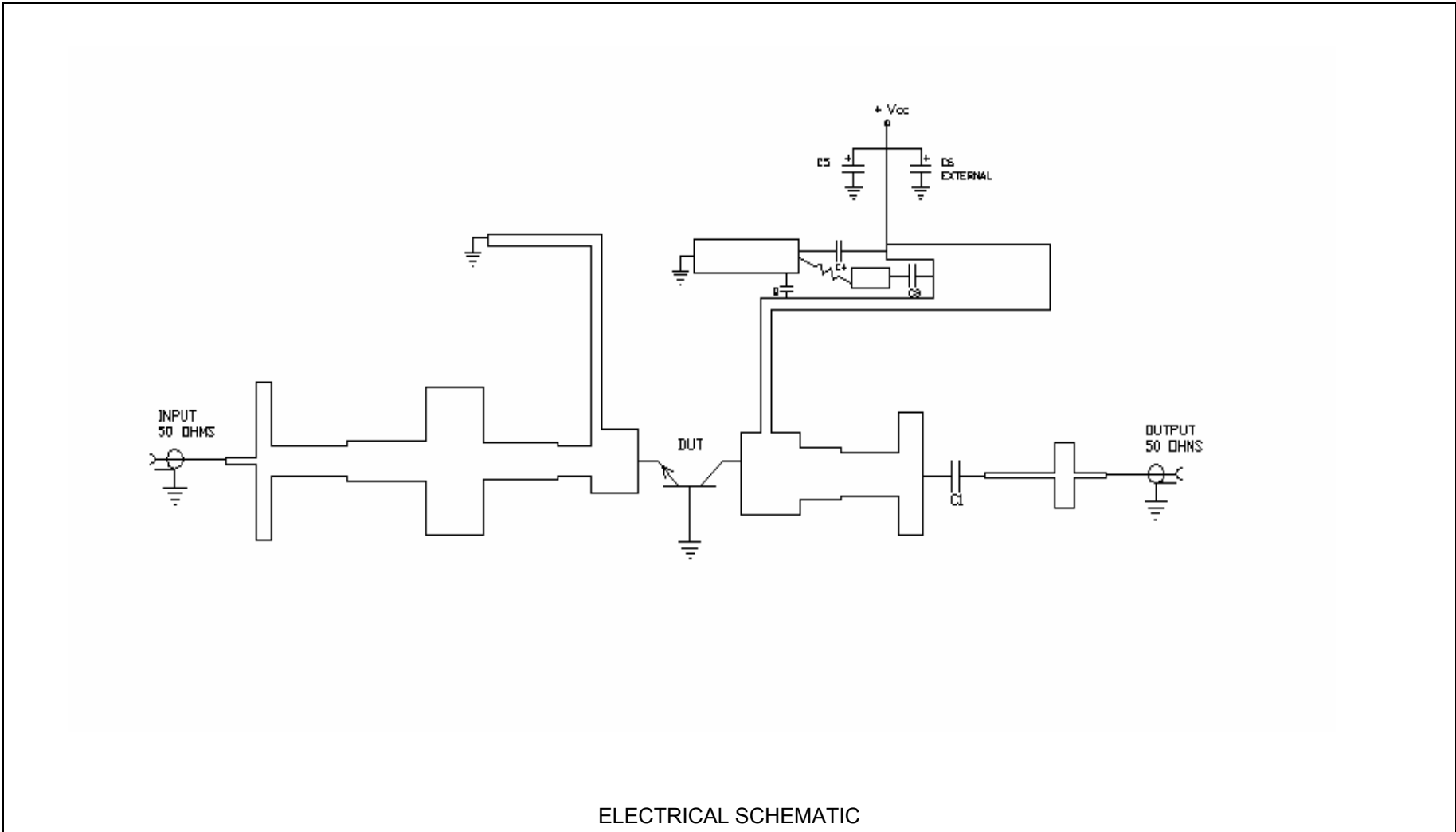

**DEFINITIONS**

<b>Data Sheet Status</b>	
Proposed Specification	This data sheet contains proposed specifications.
Preliminary Specification	This data sheet contains specifications based on preliminary measurements and data.
Product Specification	This data sheet contains final product specifications.
<b>Maximum Ratings</b>	
Stress above one or more of the maximum ratings may cause permanent damage to the device. These are maximum ratings only. Operation of the device at these or at any other conditions above those given in the characteristics sections of the specification is not implied. Exposure to maximum values for extended periods of time may affect device reliability.	

**WARNING**

<b>Product and environmental safety - toxic materials</b>
This product contains beryllium oxide. The product is entirely safe provided that the BeO base is not damaged. All persons who handle, use or dispose of this product should be aware of its nature and of the necessary safety precautions. After use, dispose of as chemical or special waste according to the regulations applying at the location of the user. It must never be thrown out with general or domestic waste.

**DISCLAIMER**

Integra Technologies Inc. reserves the right to make changes without further notice to any products herein. Integra Technologies Inc. makes no warranty, representation or guarantee regarding the suitability of its products for any particular purpose, nor does Integra Technologies Inc. assume any liability arising out of the application or use of any product or circuit, and specifically disclaims any and all liability, including without limitation consequential or incidental damages. Integra Technologies Inc. products are not designed for use in life support appliances, devices, or systems where malfunction of these products can reasonably be expected to result in personal injury. Integra Technologies Inc. customers using or selling these products for use in such applications do so at their own risk and agree to fully indemnify Integra Technologies Inc. for any damages resulting from such improper use or sale.
--