

Part Number: IGN5259M15 (Preliminary)

Integra

TECHNOLOGIES, INC.

C-Band Radar Transistor

IGN5259M15 is an internally pre-matched, gallium nitride (GaN) high electron mobility transistor (HEMT). This part is designed for C-Band radar applications operating over the 5.2 – 5.9 GHz instantaneous frequency band. Under 300us / 10% pulse conditions it supplies a minimum of 15 watts of peak output power with 15dB gain typically. Specified operation is with Class AB bias. When appropriately rated, it is operable under a wide range of pulse widths and duty factors. It operates with spectral purity into all phases of 3:1 output load VSWR. All devices are 100% screened for large signal RF parameters in a fixed tuned broadband matching circuit / test fixture. The use of external tuners is not allowed during screening.



GaN on Silicon Carbide FET

- High Power Gain
- Excellent thermal stability
- Gold Metal

Depletion Mode Device

- Negative Gate Voltage to Bias
- Bias Sequencing Required
- See App Note to Prevent Damage

Gold Metal System

- Complete Gold System
- Gold Bond Wires
- Gold Package Metal
- Maximum Reliability

Class AB

- Specified with AB bias

Internal Impedance Matching

- Ease of Use
- Input and Output
- Ultra Low Loss Design

Metal - Ceramic Package

- Metal Based
- Epoxy Seal

High Power RF Test / Fixture

- Broadband
- Matched to 50 Ω (ohms)
- Long-term Correlation
- 100% Device RF Screening
- No External Tuning required

SAMPLE DEVELOPMENT DATA

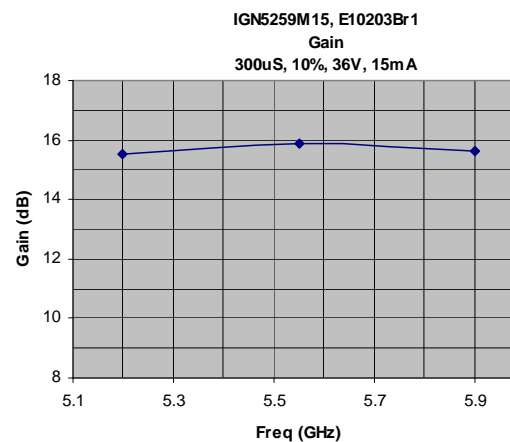
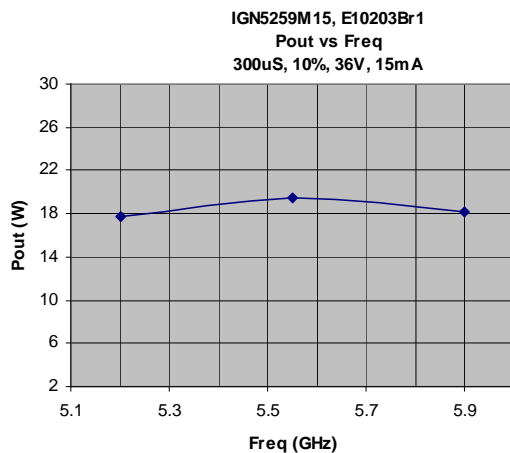

MAXIMUM RATINGS

Screen	Parameter	Symbol	Min	Max	Units	Test Conditions
BD	Drain-Source Voltage	V_{DS}	--	40	V	--
BD	Gate-Source Voltage	V_{GS}	-12	0	V	--
BD	Storage Temperature Range	T_{STG}	-55	+150	°C	--
BD	Operating Junction Temperature Range	T_J	-55	+200	°C	--
Note	Screen 'BD' = parameter qualified By Design.					

THERMAL CHARACTERISTICS

Screen	Parameter	Symbol	Min	Max	Units	Test Conditions
BD	Thermal Resistance	$R_{TH(JC)}$	--	1.41	°C/W	$V_{DD}=V1, I_{DQ}=I_{DQ1}, PW=PW1, DF=DF1, T_F=25\pm5^\circ C, P_{OUT}=15W, N_D=45\%$
Note	Screen 'BD' = parameter qualified By Design.					

PROCESSING SPECIFICATIONS

Screen	Parameter	Symbol	Min	Max	Units	Test Conditions
100%	DC Wafer Probe	--	--	--	--	Per Integra specification.
Q1	Wafer DC and RF Qualification	--	--	--	--	Per Integra specification.
LM	Wire Bond Strength	--	--	--	--	Line monitor per Integra specification.
100%	Pre-cap visual inspection	--	--	--	--	Per Integra specification
100%	Gross leak test	--	--	--	--	MIL-STD-750D, Method 1071.6, Test Condition C
Note	Screen 'Q1' = parameter is qualified by assembly and test of 3 pieces minimum per wafer.					
Note	Screen 'LM' = parameter is qualified by assembly line monitor.					



DC ELECTRICAL CHARACTERISTICS

Screen	Parameter	Symbol	Min	Max	Units	Test Conditions
100%	Drain-Source Breakdown Voltage	BV_{DSS}	80	--	V	$I_{DS} = 1mA, V_{GS} = -8V, T_F = 25\pm5^\circ C$
BD	Drain Leakage Current	I_{DSS}	--	2.0	mA	$V_{DS} = 80V, V_{GS} = -8V, T_F = 25\pm5^\circ C$
100%	Operating Gate Voltage	V_{GS}	-4.0	-2.5	V	$V_{DS} = 36V, I_D = 0.100A, T_F = 25\pm5^\circ C$
BD	Gate Leakage Current	I_{GSS}	--	1.0	mA	$V_{GS} = -8V, V_{DS} = 36V, T_F = 25\pm5^\circ C$

RF ELECTRICAL CHARACTERISTICS

Screen	Parameter	Symbol	Min	Max	Units	Test Conditions
100%	Input Return Loss	RL	-18	-7	dB	$V_{DD}=V1, I_{DQ}=I_{DQ1}, PW=PW1, DF=DF1, T_F=T_{F1}, P_{IN}=P_{IN1}, F=F1, F2, F3.$
100%	Output Power	P_O	15	25	W	$V_{DD}=V1, I_{DQ}=I_{DQ1}, PW=PW1, DF=DF1, T_F=T_{F1}, P_{IN}=P_{IN1}, F=F1, F2, F3.$
100%	Drain Current – Peak	I_D	0.85	1.00	A	$V_{DD}=V1, I_{DQ}=I_{DQ1}, PW=PW1, DF=DF1, T_F=T_{F1}, P_{IN}=P_{IN1}, F=F1, F2, F3.$
100%	Pulse Amplitude Droop	Droop	0.5	-0.5	dB	$V_{DD}=V1, I_{DQ}=I_{DQ1}, PW=PW1, DF=DF1, T_F=T_{F1}, P_{IN}=P_{IN1}, F=F1, F2, F3.$
100%	Power Gain	G_p	14.8	17.0	dB	$V_{DD}=V1, I_{DQ}=I_{DQ1}, PW=PW1, DF=DF1, T_F=T_{F1}, P_{IN}=P_{IN1}, F=F1, F2, F3.$
100%	3:1 Load Mismatch Stability	VSWR-S	S	--	--	$V_{DD}=V1, I_{DQ}=I_{DQ1}, PW=PW1, DF=DF1, T_F=T_{F1}, P_{out}=40W, F=F1, F2, F3.$ Rotate 3:1 output VSWR through 360° phase. No oscillatory or pulse break-up characteristics allowed on detected output pulse. All non-harmonically related signals must be at least -65 dBc.
Note 1	$V1 = 36V; I_{DQ1} = 15mA; PW1 = 300us; DF1 = 10%$					
Note 2	Input Power Test Levels: $P_{IN1} = 0.5W$					
Note 3	Test Frequencies: $F1 = 5.20\text{ GHz}, F2 = 5.55\text{ GHz}, F3 = 5.90\text{ GHz}.$					
Note 4	$T_{F1} = 25\pm5^\circ\text{C}$ = Device flange temperature.					
Note 5	Screen 'BD' = parameter qualified By Design.					

RF TEST FIXTURE IMPEDANCE CHARACTERISTICS

Frequency (GHz)	Z_{IF} (Ω)	Z_{OF} (Ω)
5.20	$7.2 - j17$	$9.4 - j3.6$
5.55	$12.1 - j13$	$10.8 - j1.5$
5.90	$9.4 - j9$	$9.2 + j0.6$
Impedance Definition		

PACKAGE DIMENSIONAL OUTLINE DRAWING

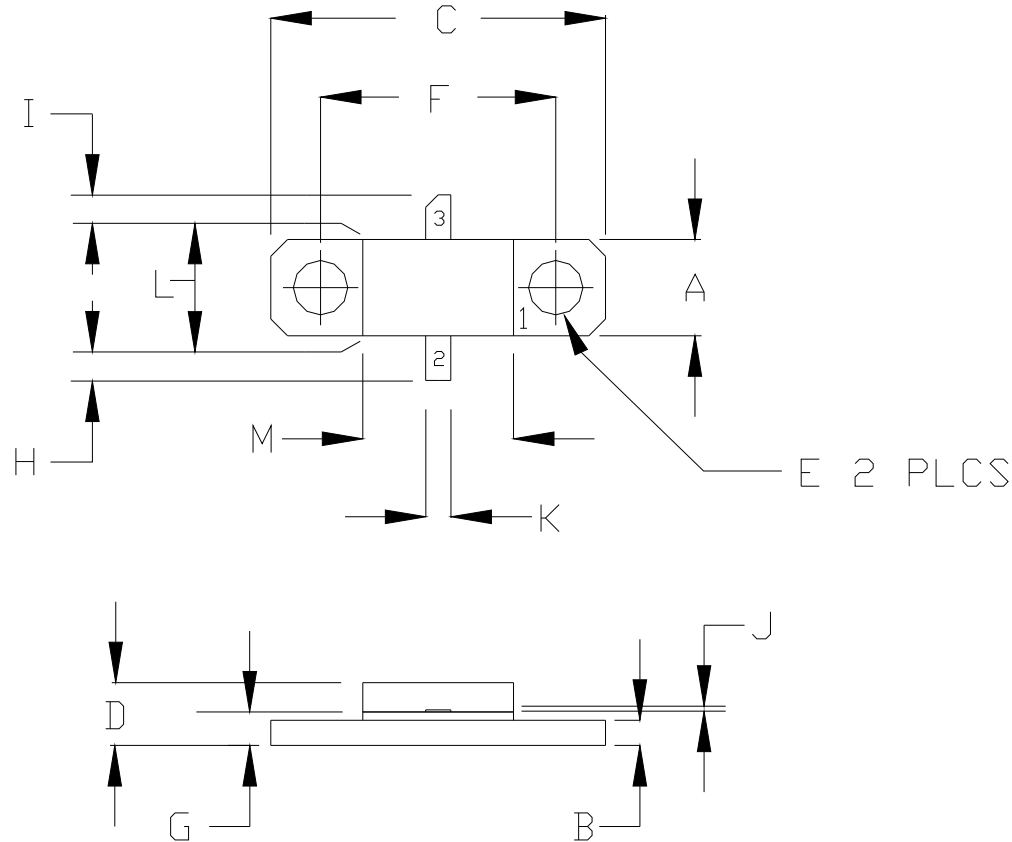

DIM	INCHES		MILLIMETERS	
	MIN	MAX	MIN	MAX
A	0.225	0.235	5.71	5.96
B	0.055	0.065	1.40	1.65
C	0.795	0.805	20.19	20.44
D	0.140	0.160	3.55	4.06
E	0.125	0.135	3.18	3.43
F	0.557	0.567	14.14	14.40
G	0.077	0.087	1.95	2.20
H	0.093	0.107	2.36	2.72
I	0.093	0.107	2.36	2.72
J	0.004	0.006	0.10	0.15
K	0.055	0.065	1.40	1.65
L	0.225	0.235	5.71	5.96
M	0.355	0.365	9.01	9.27

PIN SCHEDULE	
1	SOURCE
2	GATE
3	DRAIN

NOTES:

LID: LID-PL32-1

RF TEST FIXTURE

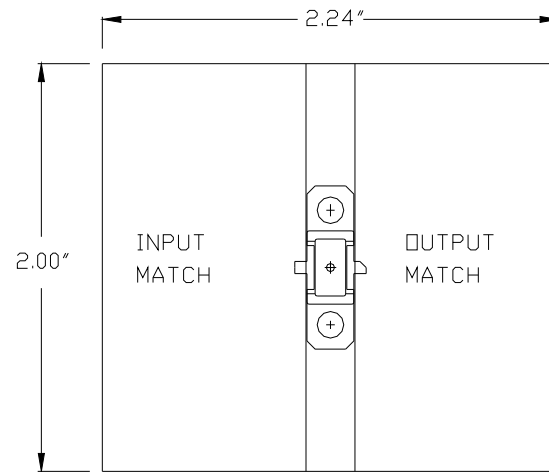

CONTACT FACTORY FOR DETAILED RF TEST FIXTURE CAD DRAWING

DEFINITIONS

Data Sheet Status	
Proposed Specification	This data sheet contains proposed specifications.
Preliminary Specification	This data sheet contains specifications based on preliminary measurements and data.
Product Specification	This data sheet contains final product specifications.
Maximum Ratings	
Stress above one or more of the maximum ratings may cause permanent damage to the device. These are maximum ratings only operation of the device at these or at any other conditions above those given in the characteristics sections of the specification is not implied. Exposure to maximum values for extended periods of time may affect device reliability.	

DISCLAIMER

Integra Technologies Inc. makes no warranty, representation or guarantee regarding the suitability of its products for any particular purpose, nor does Integra Technologies Inc. assume any liability arising out of the application or use of any product or circuit, and specifically disclaims any and all liability, including without limitation consequential or incidental damages. Integra Technologies Inc. products are not designed for use in life support appliances, devices, or systems where malfunction of these products can reasonably be expected to result in personal injury. Integra Technologies Inc. customers using or selling these products for use in such applications do so at their own risk and agree to fully indemnify Integra Technologies Inc. for any damages resulting from such improper use or sale.